

**Construction of Cable: 300/500V Non-Armoured Instrumentation Cable
(Overshielded - TRIAD)**

Drawing:

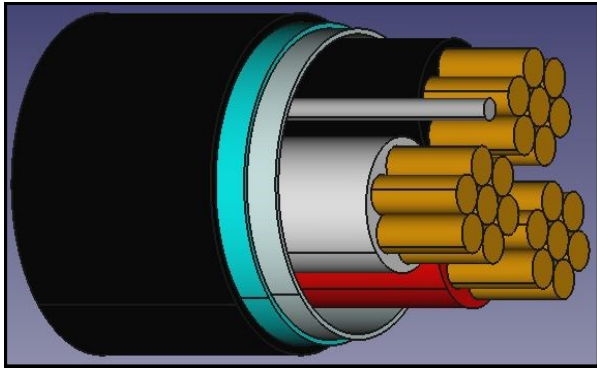

Application:

Instrumentation non-armoured cables are generally used in the petroleum and petrochemical industries. These cables are generally for indoor control applications and they are designed for use in intrinsically safe system. The cables are overall shielded for isolation and noise reduction.

NO.	DESCRIPTION	XLPE Insulated PVC Sheathed
1	Conductor	Circular stranded plain annealed copper wire according to IEC60228
2	Identification of cores: Single triad – Black, White and Red Multi triads and above: Number 1, 2, 3... and the number shall be yellow or black printed on White cores.	Cross-linked polyethylene (XLPE) according to BS EN50288-1
3	Laying Up	Triads stranded together. Binder tape and non-hygroscopic filler may be applied where necessary
4	Overall Screen	Aluminium polyester tape with metallic side downward in contact with a 0.5mm ² tinned copper drain wire (OPTIONAL)
5	Outer sheath shall be black	PVC type ST2 according to BS EN50288-1

TECHNICAL DATA

1	Voltage	300/500V
2	Maximum Conductor Temperature	90°C
3	Reference	BS EN50288-7
4	Testing Voltage	1000V
5	Minimum Bending Radius	8 X Bending Radius