

**Construction of Cable: 300/500V Armoured Instrumentation Cable
(Overshell Screened - PAIR)**

Drawing:

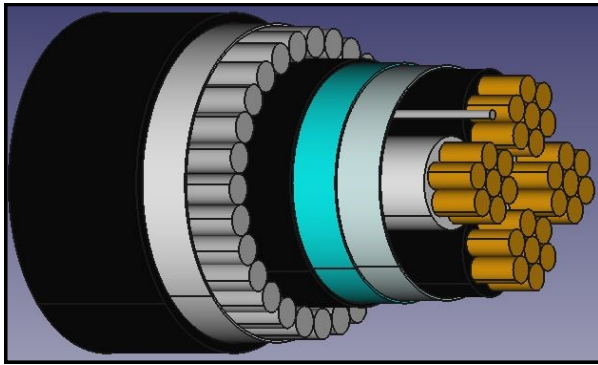

Application:

Instrumentation armoured cables are generally used in the petroleum and petrochemical industries. These cables are suitable for burial underground and they are designed for use in intrinsically safe system. The cables are overall shielded for isolation and noise reduction.

NO.	DESCRIPTION	PVC Insulated PVC Sheathed
1	Conductor	Circular stranded plain annealed copper wire according to IEC60228
2	Identification of cores: Single pair – Black and White Multi pairs and above: Number 1, 2... and the number shall be yellow or black printed on White cores.	Polyvinyl chloride compound (PVC) type TII according to BS EN50288-1
3	Laying Up	Pairs stranded together. Binder tape and non-hygroscopic filler may be applied where necessary
4	Overall Screen	Aluminium polyester tape with metallic side downward in contact with a 0.5mm ² tinned copper drain wire (OPTIONAL)
5	Separation sheath shall be black	PVC type TM5 1 according to BS EN50288-1
6	Armour	Single layer of galvanized steel wire Binder tape may be applied where necessary
7	Outer sheath shall be black	PVC type TM5 1 according to BS EN50288-1

TECHNICAL DATA

1	Voltage	300/500V
2	Maximum Conductor Temperature	70°C
3	Reference	BS EN50288-7
4	Testing Voltage	1000V
5	Minimum Bending Radius	8 X Bending Radius